



Shenzhen Haili Link Technology Co., Ltd

Product Specification Sheet

RoHS Compliant 10Gb/s SFP+ 1310nm 10km Optical Transceiver



SHENZHEN HAILI LINK CO., LTD

www.hilinktech.com



Product Features

- Supports 9.95 to 10.5Gb/s bit rates
- Duplex LC connector
- Hot pluggable SFP+ footprint
- Uncooled 1310nm DFB transmitter, PIN photo-detector
- Applicable for 10km SMF connection
- Low power consumption, < 1W
- Digital Diagnostic Monitor Interface
- Optical interface compliant to IEEE 802.3ae 10GBASE-LR
- Electrical interface compliant to SFF-8431
- Operating case temperature:
 - Commerical: 0 to 70 °C
 - Industrial: -40 to 80 °C

Applications

- 10GBASE-LR/LW at 10.3125Gbps
- 10G Fiber Channel
- Other optical links

Product Descriptions

HILINK HLSP311XL-C(I)D10 Enhanced Small Form Factor Pluggable SFP+ transceivers are designed for use in 10-Gigabit Ethernet links up to 10km over SingleMode fiber. They are compliant with SFF-8431, SFF-8432 and IEEE 802.3ae 10GBASE-LR/LW. The transceiver designs are optimized for high performance and cost effective to supply customers the best solutions for telecommunication.

Functional Diagram

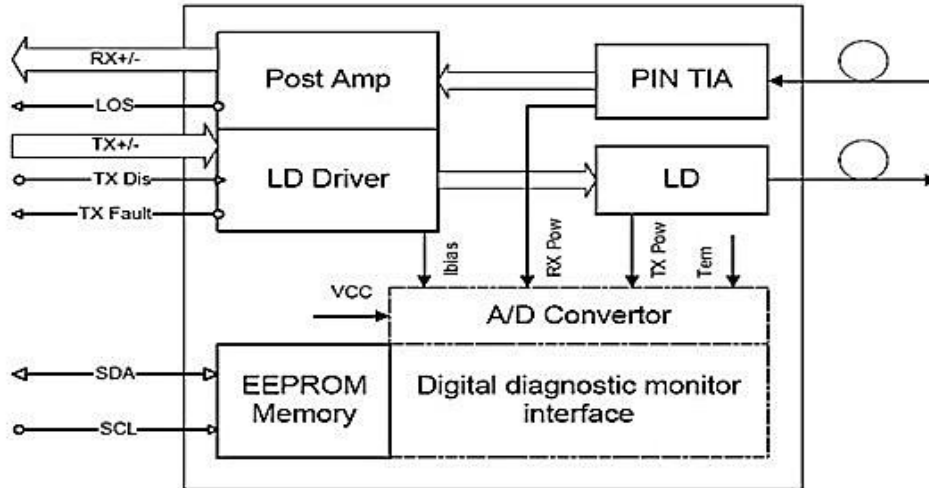

Absolute Maximum Ratings

Parameter	Symbol	Min.	Max.	Unit	Note
Supply Voltage	Vcc	-0.5	4.0	V	
Storage Temperature	Ts	-40	85	°C	
Relative Humidity	RH	0	85	%	

Note: Stress in excess of the maximum absolute ratings can cause permanent damage to the transceiver.

General Operating Characteristics

Parameter	Symbol	Min.	Typ	Max.	Unit	Note
Data Rate		9.953	10.3125	10.518	Gb/s	
Supply Voltage	Vcc	3.13	3.3	3.47	V	
Supply Current	Iccs			285	mA	
Operating Case Temp.	Tc	0		70	°C	
	Tl	-40		80		

Electrical Characteristics (TOP(C) = 0 to 70 °C, TOP(I) = -40 to 80 °C, VCC = 3.13 to 3.47 V)

Parameter	Symbol	Min.	Typ	Max.	Unit	Note
-----------	--------	------	-----	------	------	------



Transmitter						
Differential data input swing	VIN _{PP}	180		700	mV _{pp}	1
Transmit Disable Voltage	V _D	V _{CC} -0.8		V _{CC}	V	
Transmit Enable Voltage	V _{EN}	V _{EE}		V _{EE} +0.8		
Input differential impedance	R _{in}		100		Ω	
Receiver						
Differential data output swing	V _{out,pp}	300		850	mV _{pp}	2
Output rise time and fall time	T _r , T _f	28			P _s	3
LOS asserted	V _{LOS_F}	V _{CC} -0.8		V _{CC}	V	4
LOS de-asserted	V _{LOS_N}	V _{EE}		V _{EE} +0.8	V	4

Note:

1. Connected directly to TX data input pins. AC coupling from pins into laser driver IC.
2. Into 100Ω differential termination.
3. 20 – 80%. Measured with Module Compliance Test Board and OMA test pattern. Use of four 1's and four 0's sequence in the PRBS 9 is an acceptable alternative.
4. LOS is an open collector output. Should be pulled up with 4.7kΩ – 10kΩ on the host board. Normal operation is logic 0; loss of signal is logic 1.

Optical Characteristics (T_{OP(C)} = 0 to 70 °C, T_{OP(I)} = -40 to 80 °C, V_{CC} = 3.13 to 3.47 V)

Parameter	Symbol	Min.	Typ	Max.	Unit	Note
Transmitter						
Operating Wavelength	λ	1260	1310	1355	nm	
Ave. output power (Enabled)	P _{AVE}	-6		0	dBm	1
Side-Mode Suppression Ratio	SMSR	30			dB	
Extinction Ratio	ER	4	4.5		dB	
RMS spectral width	Δλ			1	nm	
Rise/Fall time (20%~80%)	T _r /T _f			50	ps	2
Dispersion penalty	T _{DP}			3.2	dB	
Relative Intensity Noise	R _{IN}			-128	dB/Hz	
Output Optical Eye	Compliant with IEEE 0802.3ae					
Receiver						
Operating Wavelength		1260		1600	nm	
Receiver Sensitivity (ER=4.5)	P _{SEN1}			-13.6	dBm	3
Receiver Sensitivity (ER=6)	P _{SEN2}			14.4	dBm	3
Overload	P _{AVE}			0.5	dBm	
LOS Assert	P _a	-30			dBm	
LOS De-assert	P _d			-18	dBm	



Shenzhen Haili Link Technology Co., Ltd

LOS Hysteresis	Pd-Pa	0.5			dB	
----------------	-------	-----	--	--	----	--

Notes:

1. Average power figures are informative only, per IEEE 802.3ae.
2. Valid between 1260 and 1355 nm.; BER<10⁻¹²; 231 – 1 PRBS.
3. Valid between 1260 and 1355 nm.Per IEEE 802.3ae.

Pin Defintion And Functions

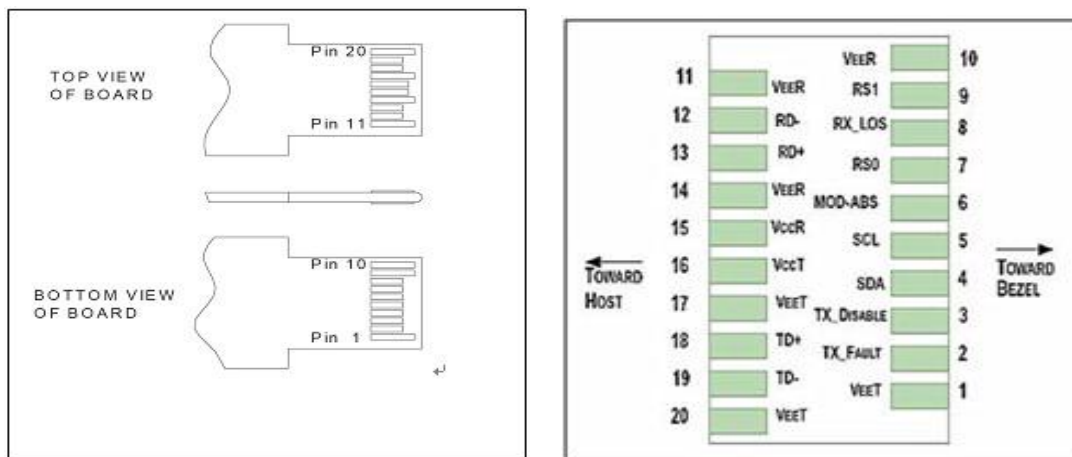

Pin	Symbol	Name/Description
1	VEET [1]	Transmitter Ground
2	Tx_FAULT [2]	Transmitter Fault
3	Tx_DIS [3]	Transmitter Disable. Laser output disabled on high or open
4	SDA [2]	2-wire Serial Interface Data Line
5	SCL [2]	2-wire Serial Interface Clock Line
6	MOD_ABS [4]	Module Absent. Grounded within the module
7	RS0 [5]	Rate Select 0
8	RX_LOS [2]	Loss of Signal indication. Logic 0 indicates normal operation
9	RS1 [5]	Rate Select 1
10	VEER [1]	Receiver Ground



11	VEER [1]	Receiver Ground
12	RD-	Receiver Inverted DATA out. AC Coupled
13	RD+	Receiver DATA out. AC Coupled
14	VEER [1]	Receiver Ground
15	VCCR	Receiver Power Supply
16	VCCT	Transmitter Power Supply
17	VEET [1]	Transmitter Ground
18	TD+	Transmitter DATA in. AC Coupled
19	TD-	Transmitter Inverted DATA in. AC Coupled
20	VEET [1]	Transmitter Ground

Notes:

1. Module circuit ground is isolated from module chassis ground within the module.
2. should be pulled up with 4.7k – 10k ohms on host board to a voltage between 3.15V and 3.6V.
3. Tx_Disable is an input contact with a 4.7 kΩ to 10 kΩ pullup to VccT inside the module.
4. Mod_ABS is connected to VeeT or VeeR in the SFP+ module. The host may pull this contact up to Vcc_Host with a resistor in the range 4.7 kΩ to 10 kΩ. Mod_ABS is asserted “High” when the SFP+ module is physically absent from a host slot.
5. RS0 and RS1 are module inputs and are pulled low to VeeT with > 30 kΩ resistors in the module.

Serial Interface for ID and DDM

The HLSP311XL-C(I)D10 transceiver support the 2-wire serial communication protocol as defined in the SFP+ MSA. The standard SFP+ serial ID provides access to identification information that describes the transceiver’s capabilities, standard interfaces, manufacturer, and other information. Additionally, This SFP+ transceivers provide an enhanced digital diagnostic monitoring interface, which allows real-time access to device operating parameters such as transceiver temperature, laser bias current, transmitted optical power, received optical power and transceiver supply voltage. It also defines a sophisticated system of alarm and warning flags, which alerts end-users when particular operating parameters are outside of a factory set normal range.

The SFP MSA defines a 256-byte memory map in EEPROM that is accessible over a 2-wire serial interface at the 8 bit address 1010000X(A0h), so the originally monitoring interface makes use of the 8 bit address(A2h), so the originally defined serial ID memory map remains unchanged. The structure of the memory map is shown in Table 1.

2 wire address 1010000X (A0h)		2 wire address 1010001X (A2h)	
Address	Information	Address	Information
0~95	Serial ID Defined by SFP MSA (96 bytes)	0~55	Alarm and Warning Thresholds (56 bytes)
		56~95	Calibration Constants (40 bytes)
96~127	Vendor Specific (32 bytes)	96~119	Real Time Diagnostic Interface (24 bytes)
		120~127	Vender Specific (8 bytes)
128~255	Reserved, SFF8079 (128 bytes)	128~247	User Writable EEPROM (120 bytes)
		248~255	Vender Specific (8 bytes)

Table 1. Digital Diagnostic Memory Map (Specific Data Field Descriptions)

Digital Diagnostic Specifications



The HLSP311XL-C(I)D10 transceivers can be used in host systems that require either internally or externally calibrated digital diagnostics.

Parameter	Symbol	Units	Min.	Max.	Accuracy	Note
Transceiver temperature	DTemp-E	°C	-45	+90	±5°C	1,2
Transceiver supply voltage	DVoltage	V	2.8	4.0	±3%	
Transmitter bias current	DBias	mA	0	127	±10%	3
Transmitter output power	DTx-Power	dBm	-6	+1	±2dB	
Receiver average input power	DRx-Power	dBm	-20	+1	±2dB	

Notes:

1. When Operating temp.=0~70 °C, the range will be min=-5, Max=+75
2. Internally measured
3. The accuracy of the Tx bias current is 10% of the actual current from the laser driver to the laser

Typical Interface Circuit

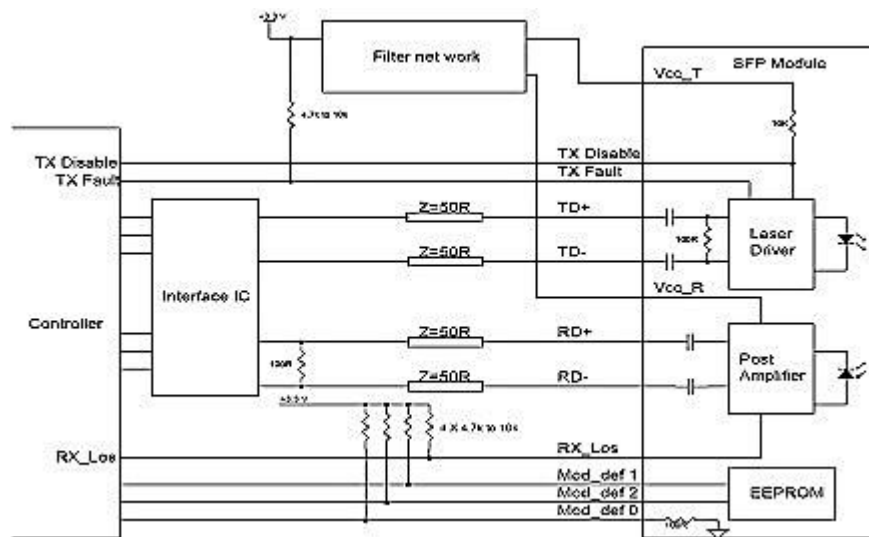

Recommended power supply filter

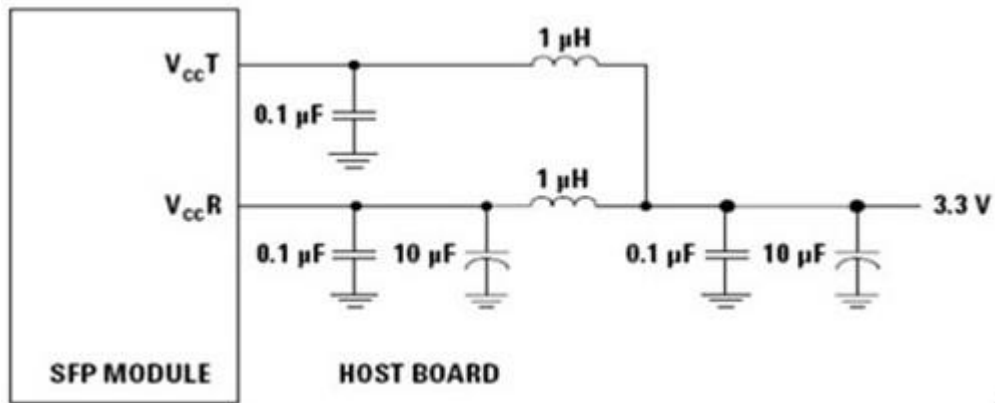
Note:

Inductors with DC resistance of less than 1Ω should be used in order to maintain the required voltage at the SFP input pin with 3.3V supply voltage. When the recommended supply filtering network is used, hot plugging of the SFP transceiver module will result in an inrush current of no more than 30 mA greater than the steady state value

Package Dimensions



Shenzhen Haili Link Technology Co., Ltd

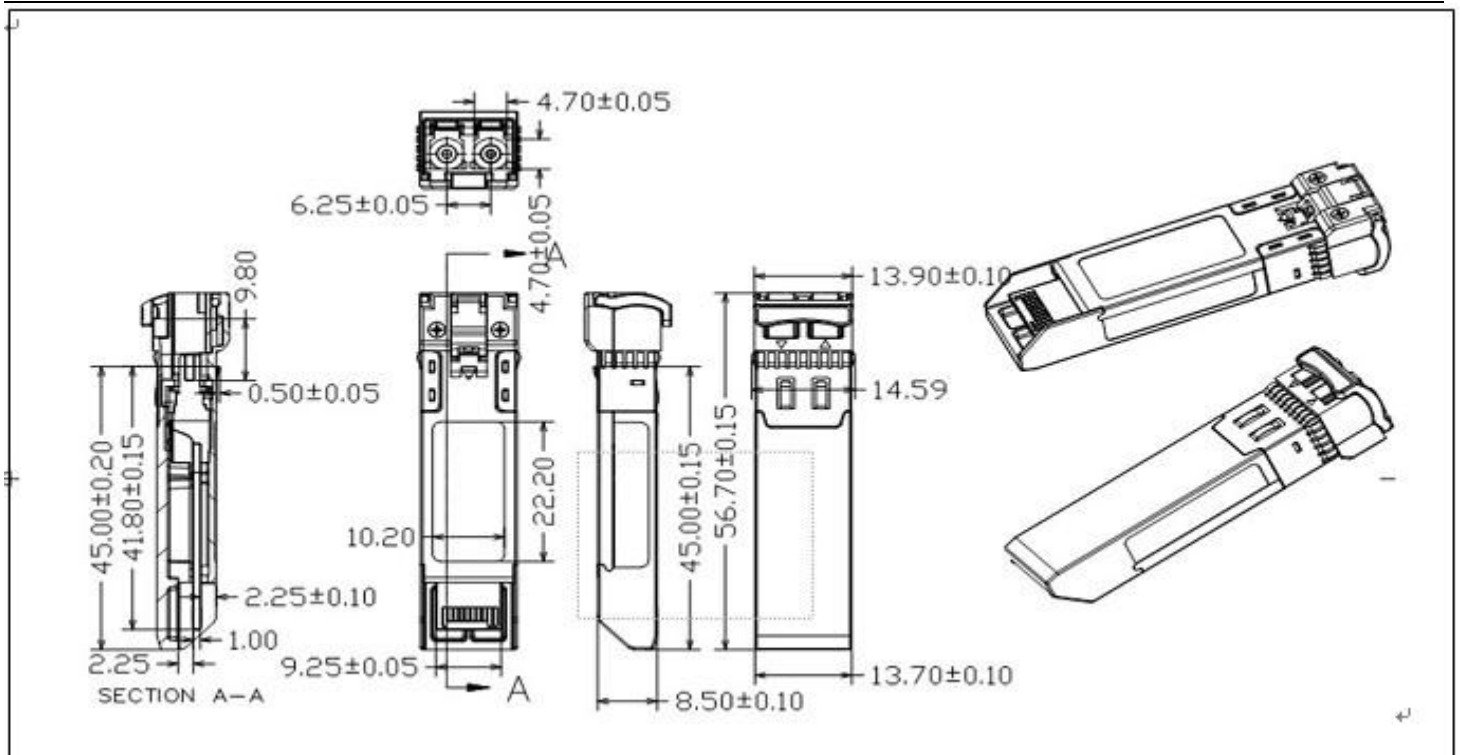

Ordering Information

Part Number	Description
HLSP311XL-CD10	SFP+,9.95 to 10.5Gb/s, 1310nm, 10km, 0~70°C, with DDM
HLSP311XL-ID10	SFP+,9.95 to 10.5Gb/s, 1310nm, 10km, -40~80°C, with DDM

For More Information

SHENZHEN HAILI HK Technology., LTD

www.hilinktech.com